

Contact
E-mail
Phone
Fax
Customer

Contact
E-mail
Phone

Tender text

Project name HiSewlift 3-35

Project ID
Installation location
Customer pos.no

Date 2016-12-12

Pos.no	Quant.	Description	PG
--------	--------	-------------	----

1		Description: Wastewater lifting unit	
1.1	1	HiSewlift 3-35 Ready-to-plug, low-noise and automatic sewage lifting unit in accordance with EN 12050-3, with all required switching and control equipment.	PG7

Components of the system:

- Reliable submersible pump with macerator
- Built-in non-return valve
- Active carbon filter
- Overflow protection
- Flexible connecting piece

Connection for a stand-alone toilet and up to three further connection options (wash basin, shower, bidet).

Local standards and directives (e.g. DIN 1986 in Germany) must be complied with during construction work.

A mains-dependent alarm is available as an option.

Materials

Pump housing : PP-GF30
Impeller : PA/PPO, fibreglass-reinforced (depending on type)
Tank material : PP
Pump shaft : 1.4305 [AISI303]

Operating data

Fluid to be pumped : Water 100 %
Volume flow :
Delivery head :
Fluid temperature : 20 °C
Min. fluid temperature : 5 °C
Max. fluid temperature : 35 °C
Maximum operating pressure : 1 bar
Max. ambient temperature : 40 °C

Motor/electronics

Mains connection : 1~230V/50 Hz
Nominal power P2 : 0,4 kW
Rated speed : 2900 1/min
Rated current (approx.) : 1,9 A
Protection class : IP 44
Insulation class : F
Permitted voltage tolerance : ±10 %

Fitting dimensions

Venting : -
Pipe connection on the suction side : DN 40
Pipe connection on the pressure side : DN 32/28/22

Information for order placements

Weight approx. : 5,675 kg
Make : Wilo
Type : HiSewlift 3-35

Item number : 4191677

Customer

Technical data

Wastewater lifting unit HiSewlift 3-35

Project name HiSewlift 3-35

Project ID
Installation location
Customer pos.no

Date 2016-12-12

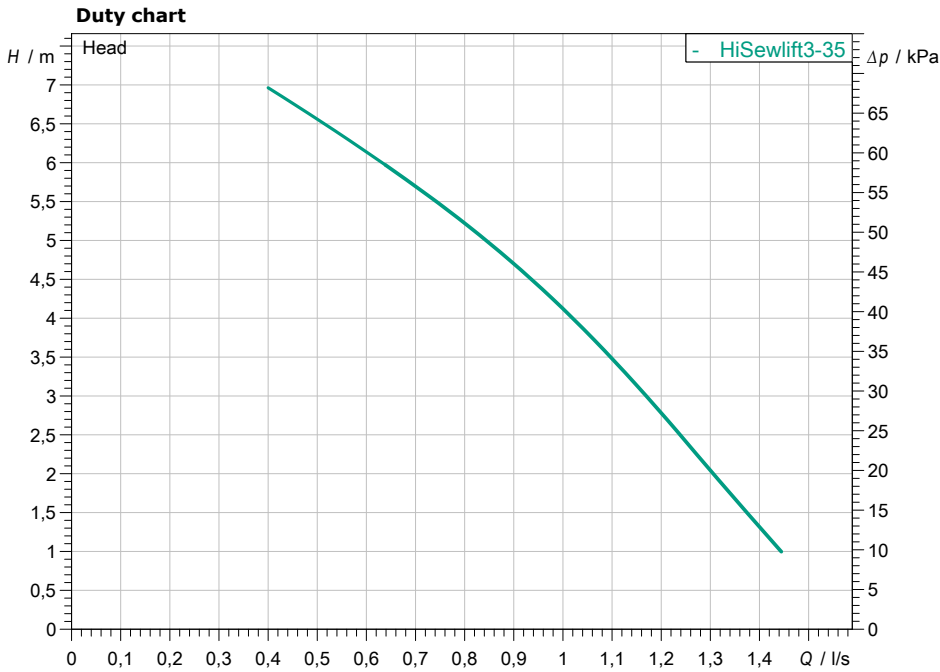

Requested data

Flow	
Head	
Media	Water 100 %
Fluid temperature	20,00 °C
Density	998,30 kg/m ³
Kin. viscosity	1,00 mm ² /s

Hydraulic data (Duty point)

Flow
Head

Product data

Wastewater lifting unit	
HiSewlift 3-35	
Max. operating pressure	100 kPa
Fluid temperature	5 °C ... + 35 °C
Grinder	yes
Operating mode (non-immersed)	S3
Gross volume	17,4 l
Max. switching volume	1 l

Motordata per Motor/Pump

Mains connection	1~ 230 V / 50 Hz
Permitted voltage tolerance	±10 %
Nominal speed	2900 1/min
Rated power P2	0,40 kW
Power input P1	0,4 kW
Rated current	1,90 A
Activation type	-
Degree of protection	IP 44
Motor protection	
Insulation class	F

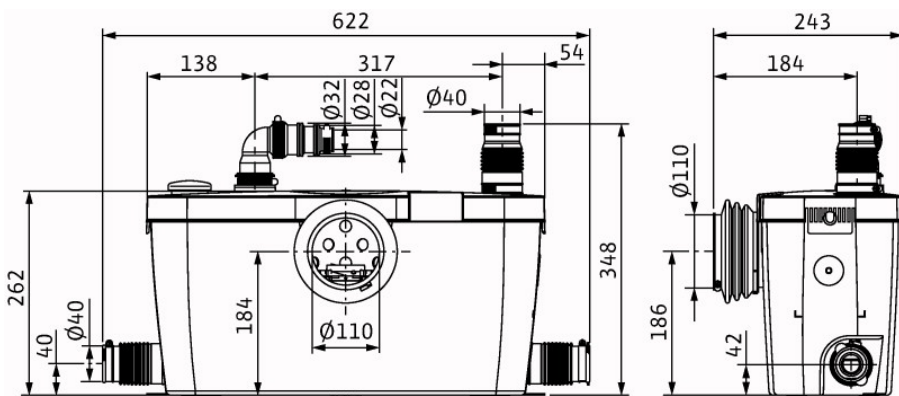

Cable

Length of connecting cable	1,5 m
Mains plug	CEE
Type of connecting cable	Non-detachable

Fitting dimensions

Venting	-
Pipe connection on the suction side	DN 40
Pipe connection on the pressure side	DN 32/28/22

Materials

Pump housing	PP-GF30
Impeller	PA/PPO, fibreglass-reinforced
Tank material	PP
Pump shaft	1.4305 [AISI303]

Information for order placements

Weight approx.	5,7 kg
Item number	4191677